

METAL DETECTOR

METRON 05 CI

RELIABLE DETECTION OF ALL METALS:

- FERROUS
- STAINLESS STEEL
- ALUMINUM
- COPPER
- BRASS
-

RELIABLE DETECTION OF FREE OR ENCAPSULATED CONTAMINANTS.

Version 07/11

CLOSED TUNNEL TYPE DETECTOR WITH INTEGRAL CONTROL BOX SUITABLE FOR INSTALLATION IN BELT CONVEYORS, GRAVITY OR VACUUM/PRESSURE CONVEYING LINES,



INDUSTRIES

- FOOD INDUSTRY
- TOILETRIES
- CHEMICAL/PHARMACEUTICAL INDUSTRY

APPLICATION

- PRODUCT INSPECTION (TO MEET THE REQUIREMENT OF ISO 9000, HACCP, ...)
- MACHINERY PROTECTION

MICRO PROCESSOR TECHNOLOGY INCLUDING DIGITAL 2 CHANNEL SIGNAL PROCESSING, ASSURING RELIABLE DETECTION EVEN AT CONVEYING SPEEDS OF UP TO 30 M/SEC.

www.mesutronic.de

MESUTRONIC

Metal Detection made in Germany

SCOPE OF DELIVERY

- DETECTOR HEAD WITH INTEGRAL CONTROL BOX
- USER MANUAL INCL. INSTALLATION INSTRUCTIONS, WIRING DIAGRAM AND SPARE PARTS LIST IN SEVERAL LANGUAGES
- EG CONFORMITY DECLARATION

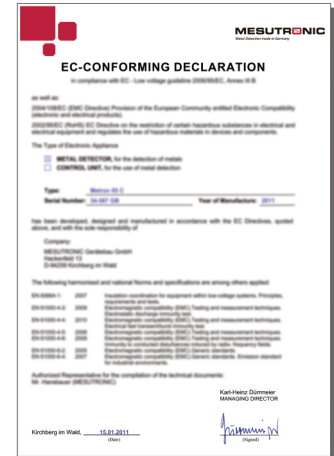

OPTIONAL EQUIPMENT

- METAL DETECTOR-TEST SPHERES
 - METAL SPHERE(S) ENCASED IN PLASTIC TO VERIFY SENSITIVITY
 - SEVERAL SIZES AND TYPES - (IF DESIRED WITH CERTIFICATE)
- WARNING DEVICE
 - BEACON
 - BUZZER
 - BEACON WITH SIREN
- HARD COPY PRINTER
 - WITH RS 232 CONNECTION (MAX. CABLE LENGTH OF 100 METERS)
 - WITH RS 422 CONNECTION (MAX. CABLE LENGTH OF 1200 METERS)
- SOFTWARE SOLUTIONS
 - mesuSET (OPERATION OF DETECTOR VIA LAPTOP)
 - mesuNET (NETWORK INTEGRATION AND REMOTE MAINTENANCE)
 - AND MORE
- REMOTE RESET DEVICE
- SOLUTIONS WITH BELT CONVEYORS AND REJECT MECHANICS TURN KEY
- REJECT SYSTEMS
 - PUSHER SYSTEMS
 - FLAP SYSTEMS
 - CUT-OUT DEVICE
 - AND MORE
- CONVEYOR CONTROLS
 - CONVEYOR REVERSE
 - AND MORE

SPECIAL VERSIONS

- EXPLOSION PROOF
- CUSTOM PAINT
- SPECIAL POWER SUPPLY
- HIGH TEMPERATURE
- ALUTRON-VERSION (NO FALSE TRIPPING BY METALLIC FILMS SUCH AS CUP LIDS,), PATENT-NO. 4342826
- DETECTOR HEAD WITH REMOTE CONTROL BOX



DIMENSIONS

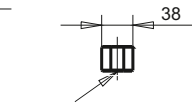
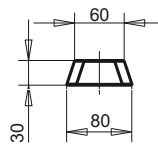
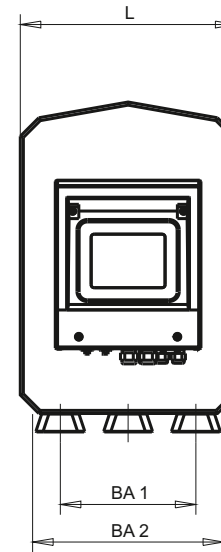
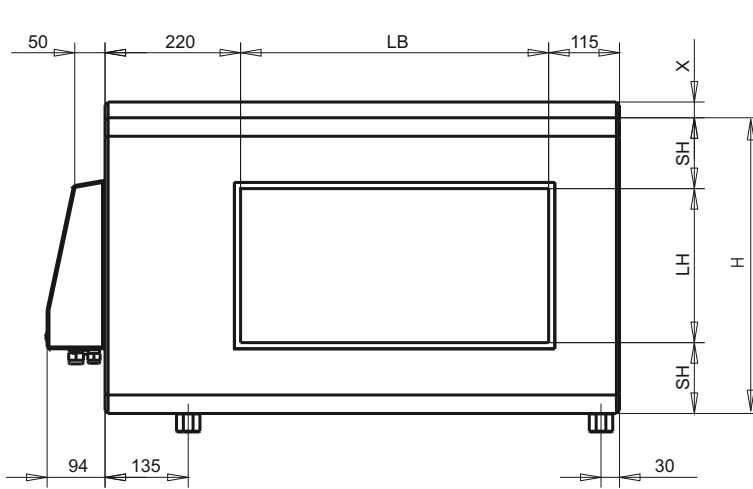

DETECTOR SUPPORT LEGS - SCREW THREAD M 12
 MAX. DEPTH OF THREAD = 18 MM
 MATERIAL POLYETHYLENE (PE)

LB (APERTURE WIDTH): AVAILABLE FROM 50 TO 2000 MM (IN 50 MM INCREMENTS)

LH APERTURE HEIGHT	L ,DETECTOR LENGTH	SH TOP/BOTTOM THICKNESS	DISTANCE BETWEEN BORE CENTRES		NUMBER OF FASTENER BORES	MARK X
			BA 1	BA 2		
50	260	150	130	-	4	18
75	260	130	130	-	4	18
100 - 150	260	115	130	-	4	18
175 - 200	300	115	170	-	4	22
225 - 250	350	115	220	-	6	26
275 - 300	400	115	230	-	6	27
325 - 350	450	115	280	-	6	31
375 - 400	500	115	110	330	8	36
425 - 450	550	115	190	380	10	40
475 - 500	600	115	215	430	10	44
550 - 600	650	115	240	480	10	49

ALL DIMENSIONS IN MM.

METAL FREE ZONE (MFZ)

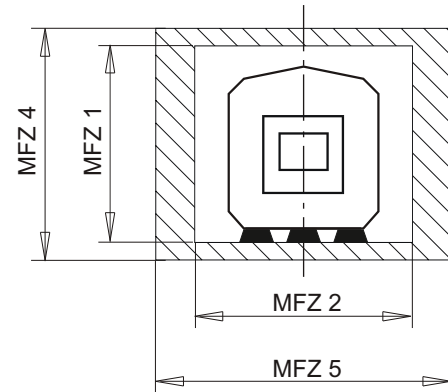
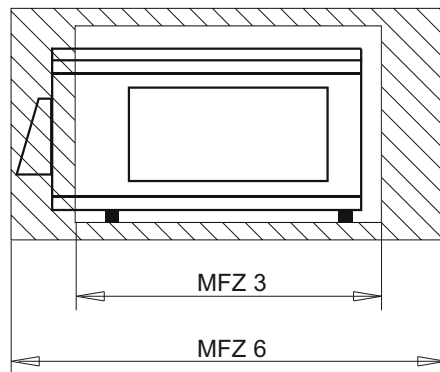

CALCULATING THE „METAL FREE ZONE“ ...

FOR NON-MOVING METALS

$$\begin{aligned} \text{MFZ 1} &= H + 60 \text{ MM} \\ \text{MFZ 2}^{1)} &= L + LH \\ \text{MFZ 3} &= LB + LH \end{aligned}$$

FOR MOVING METALS

$$\begin{aligned} \text{MFZ 4} &= 3 LH + 2 SH + 60 \text{ MM} \\ \text{MFZ 5}^{1)} &= L + 3,5 LH \\ \text{MFZ 6} &= LB + 3 LH \end{aligned}$$



¹⁾ POSITION THE DETECTOR APERTURE IN THE MIDDLE OF THE „METAL FREE ZONE“
FOR THE OTHER DIMENSIONS: POSITION THE DETECTOR SYMMETRICAL IN RELATION TO THE APERTURE.

THE CALCULATED DIMENSIONS ARE TO BE TAKEN AS ORIENTATION VALUES (MINIMUM VALUES WHICH SHOULD BE EXCEEDED.) AND HAVE TO BE VERIFIED BY THE MANUFACTURER, DEPENDING ON THE PROJECT. MAKE THE „METAL FREE“ ZONE AS LARGE AS POSSIBLE. „NON-MOVING“ METALS ARE CONVEYOR FRAMES AND COIL SUPPORTS. (BUT NOT THE TRAVERSE CONNECTIONS BETWEEN SUCH EQUIPMENT!) MOVING METALS ARE DIVERTER AND DRIVE ROLLERS OR FOR EXAMPLE THE AXIS OF A REJECT PUSHER. PAY PARTICULAR ATTENTION TO MOVING GATES AND MACHINES OR MACHINE PARTS WHICH CHANGE THEIR DISTANCE TO THE METAL DETECTOR OR WHICH MOVE IN THE VICINITY OF THE APERTURE. IF THE METAL FREE ZONE CANNOT BE MAINTAINED DUE TO SPACE RESTRICTIONS FALSE REJECTS AND OR REDUCED SENSITIVITY CAN BE EXPECTED.

IN ADDITION, PLEASE OBSERVE OUR „ HINTS FOR THE INSTALLATION OF SEARCH COILS“ !

SENSITIVITY DIAGRAM

VALID IF $LB \leq 1,5 \times LH$

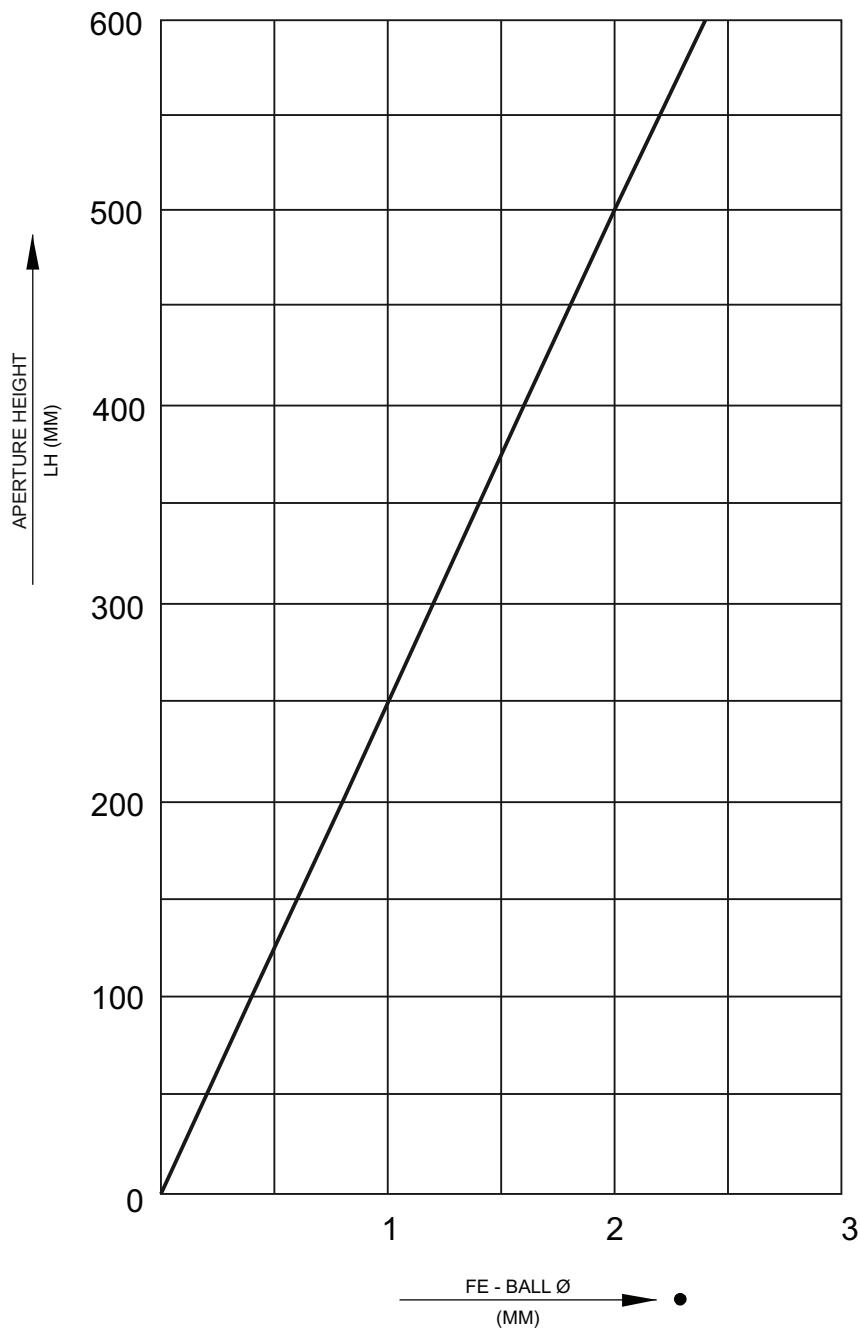

THE SENSITIVITY DEPENDS ON THE DETECTION COIL APERTURE - THE SMALLER THE OPENING, THE HIGHER THE SENSITIVITY.

BASIC SENSITIVITY

MANY METAL DETECTOR MANUFACTURERS STATE IN THEIR OFFERS OR BROCHURES SENSITIVITIES ACHIEVED UNDER LABORATORY CONDITIONS WHICH DO NOT TAKE PROCESS CONDITIONS, SUCH AS PRODUCT EFFECT OR THE PROCESS ENVIRONMENT INTO CONSIDERATION. SUCH SENSITIVITIES DO NOT ALLOW FOR CONCLUSIONS TO THE REAL CAPABILITIES OF THE UNIT. ONLY THE SENSITIVITY UNDER OPERATING CONDITIONS ALLOWS FOR CONCLUSIONS HOW WELL A METAL DETECTOR PROTECTS AGAINST LOSS OF IMAGE AND LIABILITY CLAIMS.

OPERATIONAL SENSITIVITY

THE SENSITIVITY LISTED IN THE DIAGRAM ARE ACHIEVED WITH MOST DRY PRODUCTS IN THE CENTER OF THE DETECTOR APERTURE UNDER TYPICAL PROCESS CONDITIONS. THE VALUES WITH HUMID OR FRESH PRODUCTS MAY DEVIATE CONSIDERABLY FROM THE VALUES STATED IN THE DIAGRAM. IF YOU SUBMIT PRODUCT SAMPLES TO OUR APPLICATIONS LAB WE WILL EVALUATE THE HIGHEST POSSIBLE SENSITIVITY FOR YOUR PRODUCT.

SENSITIVITY FOR OTHER METALS:

- STAINLESS STEEL (SS 316) = FE-BALL x 1,6
- ALLOYS SUCH AS BRASS (MS) = FE-BALL x 1,2

CONTROL UNIT AMD 05 (Version 5.2)

ADVANTAGES THAT WILL CONVINCING YOU!

SINGLE BOARD DESIGN WITH BUILT IN REGULATED POWER SUPPLY FOR RELIABLE PERFORMANCE AND EASE OF SERVICE.

AUTO-SETUP-ROUTINE WITH INTERFERENCE SIGNAL SUPPRESSION AND AUTOMATIC SENSITIVITY CALIBRATION.

MULTI-FILTER SYSTEM USING DIGITAL FILTRATION FOR MAXIMUM STABILITY IN HARSH ENVIRONMENTS.

AUTO-BALANCE AUTOMATICALLY DETECTS AND COMPENSATES FOR ANY CHANGES IN THE SIGNAL DURING NORMAL OPERATION. (E.G. TEMPERATURE VARIATIONS)

SELF MONITORING SYSTEM ENSURES ALL IMPORTANT COMPONENTS ARE FUNCTIONING PROPERLY. IN CASE OF A FAULT, RELAY OUTPUTS ARE AVAILABLE. FAULTS ARE DISPLAYED AS TEXT IN REAL TIME.

NARROW DETECTION ZONE PROVIDES AN ACCURATE LOCATION OF THE METALLIC PARTICLE IN THE DETECTION FIELD ALLOWING PRECISE SEPARATION.

TOUCHPAD CONTROLS MODERN DESIGN. RUGGED TOUCHSCREEN FOIL WITH ERGONOMIC CONTROLS.

4 BUTTON TOUCHPAD CONTROLS SUPPORTED BY EASY TO UNDERSTAND MENUS FAST ACCESS TO ALL OPERATING PARAMETERS. USER SELECTABLE DIALOG LANGUAGE.

5-LINE BACK-LIT LCD DISPLAY WITH METAL SIGNAL INDICATION. ADDITIONAL LED INDICATOR LAMPS ARE BUILT IN TO INDICATE METAL DETECTION OR FAULTS.

METAL COUNTER CAN BE DISPLAYED ON THE LCD SCREEN OR INTERFACED WITH A PRINTER OVER A SERIAL INTERFACE.

3-LEVEL PASSWORD PROTECTION WITH INTER-CHANGEABLE CODE NUMBERS.



PRODUCT STORAGE MEMORY BACKUP FOR UP TO 500 INDIVIDUAL PRODUCTS. EACH PRODUCT HAS A COMPLETE SET OF ADJUSTMENT DATA ASSIGNED, SUCH AS SENSITIVITY, REJECT TIME ETC. THE DISPLAY OF TIME RELEVANT DATA IS IN REAL-TIME. INDIVIDUAL PRODUCT NAMES CAN BE STORED AS WELL.

METAL DETECTOR NETWORK AND REMOTE SERVICE

EVERYTHING IS DO-ABLE! SEVERAL OPTIONAL SOFTWARE-PACKAGES ARE AVAILABLE. EXAMPLE: WITH THE BUILT-IN CAN-BUS-DATA PORT A NETWORK OF UP TO 125 METAL DETECTORS / SEPARATORS CAN BE OPERATED. THE UNITS CAN THEN BE REMOTE CONTROLLED AND OPERATED VIA A CENTRAL PC. ALSO REMOTE DIAGNOSIS, PARAMETER CHANGE AND SOFTWARE UPDATES VIA MODEM ARE POSSIBLE.

SERIAL DATA PORT

FOR DIFFERENT TASKS. THE METAL DETECTOR IS EQUIPPED WITH 1 SERIAL DATA PORT (RS 232). HOWEVER THIS PORT IS RESERVED FOR FACTORY SERVICE ACCESS SUCH AS ADJUSTMENT DATA LOGGING, SOFTWARE UPDATES ETC.) AS AN OPTION, THIS DATA PORT MAY ALSO BE USED BY THE CLIENT (SWITCHABLE). IT CAN BE USED TO DRIVE A LOCAL OR CENTRAL PROTOCOL PRINTER. THE PROTOCOL LAYOUT CONFORMS TO ISO 9000 AND HACCP GUIDELINES. BI-DIRECTIONAL DATA COMMUNICATION WITH CUSTOMER'S SPS OR PC SYSTEMS IS AVAILABLE (OPTIONAL SOFTWARE PACKAGE).

ACTIVE QUALITY ASSURANCE

WITH SMD COMPONENTS SAVE NOT ONLY SPACE BUT ALSO ASSURE OPTIMUM QUALITY AND SAFETY FOR THE END USER. WITH AUTOMATED PLACEMENT COMPONENT ERRORS ARE ELIMINATED. IN ADDITION EACH CARD IS 100% TESTED AND ARTIFICIALLY AGED. ALL MESUTRONIC PRODUCTS ARE DEVELOPED UNDER DIN, EN AND UVV STANDARDS AND COMPLY WITH THE STRICT CE STANDARDS AS WELL.

CONTROLS

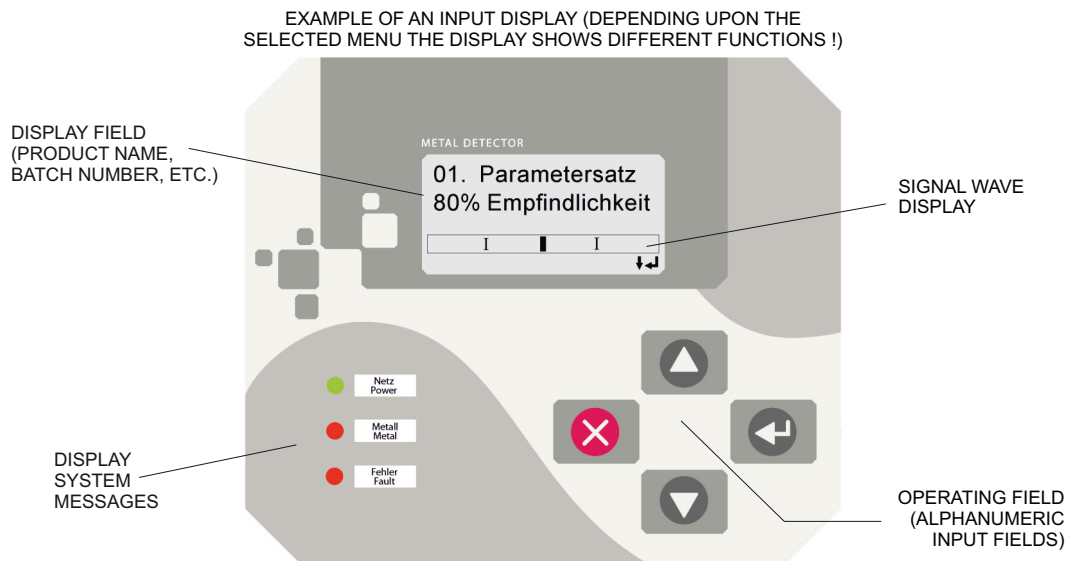

ELECTRONIC BOX

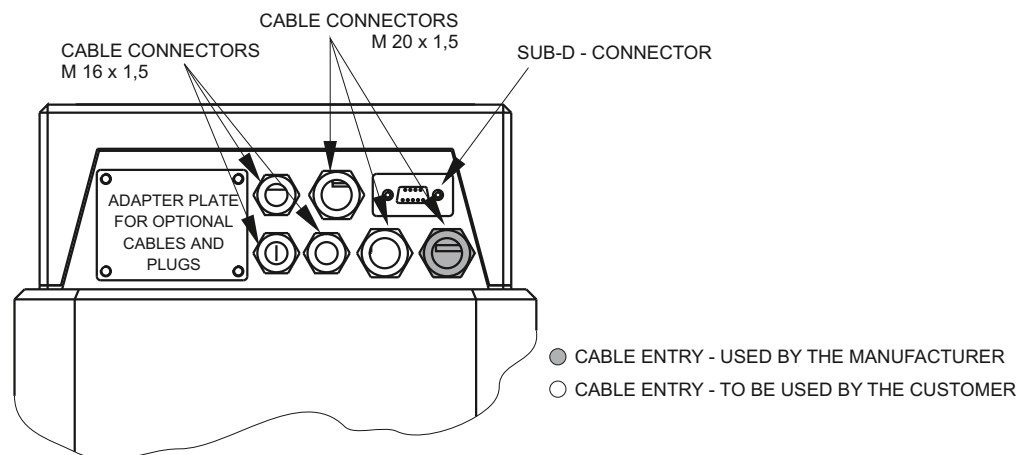

TECHNICAL DATA

POWER SUPPLY:	100 - 240 V AC, 50/60 HZ
POWER CONSUMPTION:	MAX. 50 W
FUSE:	1,25 A (SLOW BLOW), 5 x 20 MM ACCORDING TO DIN
TYPE OF PROTECTION:	IP 66 (OPTIONAL IP 69K)
WORKING TEMPERATURE RANGE:	- 10° C TO + 50° C
STORAGE TEMPERATURE RANGE:	- 10° C TO + 60° C
REL. HUMIDITY:	0 - 95 % (WITHOUT CONDENSATION)
CONVEYING SPEED:	0,02 TO 30 M/SEK.
VERSION:	MADE OF ALUMINIUM, PAINTED (RAL 9007) OR STAINLESS STEEL SENSING AREAS MADE OF POLYPROPYLENE
POWER CABLE:	APP. 1,8 M CABLE WITH PLUG (TWO POLE AND EARTHING PIN) (US-VERSION WITH US-STANDARD PLUG)

OTHER VERSIONS AVAILABLE

LAYOUT AMD 05

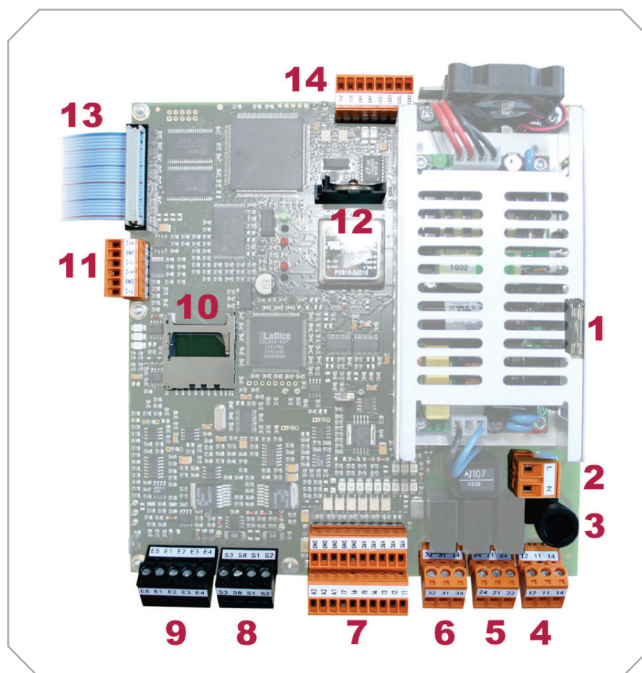

- 1.** SPARE FUSE
- 2.** POWER SUPPLY 100 - 240 VAC, 50/60 HZ
- 3.** DEVICE FUSE 1,25 A (SLOW BLOW) 5 x 20 MM ACCORDING TO DIN



- 4.** RELAY 1 (SWITCHES NORMALLY ON METAL)
POTENTIAL FREE CONTACT
FROM FACTORY (IF NOT REQUESTED OTHERWISE)
RELAY 1 IS DESTINATED AS METAL-RELAY
MAX. CONTACT LOAD: 250 V/3 A



- 5.** RELAY 1 (SWITCHES NORMALLY ON OPERATION)
POTENTIAL FREE CONTACT
ASIDE FROM THE OPTICAL DISPLAY A POTENTIAL FREE
CONTACT IS AVAILABLE TO POLL THE UNIT CONDITION
MAX. CONTACT LOAD: 250 V/3 A



- 6.** RELAY 3 (TO BE CONFIGURED BY THE MANUFACTURER)
POTENTIAL FREE CONTACT
MAX. CONTACT LOAD: 250 V/3 A

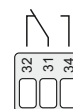

LAYOUT AMD 05

- 7.** SEVEN (7) FREE PROGRAMABLE INPUTS (24V DC)
AND THREE (3) FREE PROGRAMABLE OUTPUTS (24V DC)

In1 - INITIATOR / BUTTON „NORMAL POSITION“
In2 - INITIATOR / BUTTON „EJECT POSITION“
In3 - AIR PRESSURE MONITOR (PRESSURE SWITCH)
In4 - INPUT LIGHT BARRIER
In5 - POSITION SENSOR
In6 - EXTERNAL RESET BUTTON
In7 - NOT CONNECTED

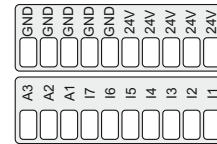

THREE (3) FREE PROGRAMABLE OUTPUTS (24V DC)
OUTPUTS (STANDARD LAYOUT)
OUT 1 - 24 V OUTPUT METAL
OUT 2 - 24 V OUTPUT READY
OUT 3 - NOT CONNECTED

ADDITIONAL CONTACT POSSIBILITIES: LEVEL SENSORS AND MORE

MAX. LOAD FOR ALL INPUTS AND OUTPUTS $I_{TOTAL} \leq 300 \text{ MA CUMULATIVE!}$

- 8.** CONNECTION SENDER (USED BY FACTORY)
9. CONNECTION RECEIVER (USED BY FACTORY)
10. SLOT FOR SD MEMORY CARD
11. CAN – BUS DATA PORT
12. BATTERY
13. CONNECTION DISPLAY (USED BY FACTORY)
14. SERIAL DATA PORT (USED BY FACTORY)

MESUTRONIC Gerätebau GmbH

A TEAM OF SPECIALISTS DEDICATED TO DEVELOP, MANUFACTURE AND MARKET THE WORLD'S FINEST ELECTRONIC METAL DETECTION AND SEPARATION EQUIPMENT FOR ALL INDUSTRIES. IT IS OUR GOAL TO PROVIDE THE OPTIMUM SOLUTION TO MEET EVERY CRITERIA. MANY YEARS OF EXPERIENCE PROVIDING HUNDREDS OF DETECTION COILS WITH VARIOUS CONTROLS AS WELL AS A MULTITUDE OF MECHANICAL SEPARATING AND SORTING COMPONENTS ARE AT YOUR DISPOSAL. WE POOL OUR KNOWLEDGE AND EXPERIENCE TO OFFER A SOLUTION TO VIRTUALLY ANY APPLICATION.

„WHEN OTHERS SAY NO, WE SAY LETS GO!“

LET OUR TEAM PROVIDE YOU WITH THE OPTIMUM SOLUTION FOR YOUR METAL CONTAMINATION.

© Copyright MESUTRONIC Gerätebau GmbH, Germany



MESUTRONIC

Metal Detection made in Germany

MESUTRONIC Gerätebau GmbH • Hackenfeld 13 • D-94259 Kirchberg, Wald
Tel.: +49- (0)9927 / 9410-0 • Fax: +49- (0)9927 / 1732
E-Mail: sales@mesutronic.de • www.mesutronic.de